

A characterization of subgroup lattices of finite Abelian groups

Christian Herrmann and Géza Takách*

Dedicated to Bjarni Jónsson.

Abstract

We show that every primary lattice can be considered a glueing of intervals having geometric dimension at least 3 and with a skeleton of breadth at most 2. We call this *geometric decomposition*. In the Arguesian case, we analyse the sub-glueings corresponding to cover preserving sublattices of the skeleton which are 2-element chains or a direct product of 2 such. We show that these admit a cover preserving embedding into the submodule lattice of a finitely generated module over a completely primary uniserial ring. It follows, that a primary Arguesian lattice can be coordinatized by such module if the skeleton of the geometric decomposition is a chain. This fails due to an example of G.S. Monk [29] if the skeleton has breadth 2. Moreover, there are non-isomorphic examples of this type having isomorphic skeletons and isomorphism between the corresponding intervals. Hence, most of the statements in sections 9 and 10 are wrong. The main results of Antonov and Nazyrova [25, 26] are wrong, too, since the subgroup lattice of $C_{p^k}^n$ ($k \geq 2$, $n \geq 3$) cannot be embedded into the subspace lattice of any vector space [28], Credit for Thm.3.1 below should be also given to [31, 27, 30]. The due Corrigenda and Addenda are given in: On the coordinatization of primary arguesian lattices of low geometric dimension, Beitr. Geom.u.Algebra 55, Issue 2 (2014), Page 649–668

Keywords and phrases: primary Arguesian lattice, completely primary uniserial ring, glueing of lattices.

Mathematics Subject Classification. 06C05, 16P20.

The lattices of all subgroups of finite Abelian p -groups and, more generally, submodules of finitely generated modules over completely primary uniserial rings have been characterized by Baer, Inaba and, finally, Jónsson and Monk [19] under the assumption that there are at least three independent cyclic subgroups

*This research was supported by the DAAD, and also by the Hungarian Ministry of Education, grant no. FKFP 0169/2001 and OTKA T034137.

of maximal order respectively submodules of maximal rank. The characteristic property is that these lattices are primary Arguesian with three independent cycles of maximal rank. These were needed in order to apply the intricate geometric coordinatization methods. They provide also the basis for the von Neumann style internal construction of the coordinate ring.

The main result of the present paper yields that primary Arguesian lattices are exactly the lattices isomorphic to lattices of all submodules of finitely generated modules over completely primary uniserial rings - only in the case that there are just 2 independent cycles (i.e. in case of breadth 2) one has to add the condition that height 2 intervals are chains or have a fixed number q of atoms where q is either infinite or $p^k + 1$ with prime p . Lattices of finite Abelian p -groups are then characterized by the fact that the coordinate ring is the integers modulo some p^n resp. $k = 1$ in breadth 2, and subgroup lattices of finite Abelian groups by having central elements providing the primary decomposition into p -groups.

The breadth 2 case is purely combinatorial and has in essence already been done by Ribeiro [22]. So the interesting case is that of breadth ≥ 3 lattices. We understand these as being glued together of maximal intervals to which the result of Jónsson and Monk applies. Extending the methods of Jónsson [16], Pickering [21], and Day et al. [8] beyond division rings and “2-dimensional gluings”, it is shown that all these intervals have the same coordinate ring R which together with the type, i.e. ranks occurring in a decomposition of 1 as direct sum of cycles, yields a complete isomorphism invariant. On the other hand, for any value of the invariant a suitable submodule lattice is constructed.

Certain special cases, where the coordinate ring is a division ring, have been dealt with by Nation and Pickering [20], Day et al. [8], and Antonov and Nazarova [1]. As compared to [8] we have to describe in more detail the machinery of local (re)coordinatizations. This is due to the more general skeletons considered and to the fact that for the blocks extension of automorphisms defined on an ideal is possible only in special circumstances (a phenomenon well known from the computation of Jordan normal forms).

1 Gluing of lattices

We consider lattices L of finite height with bounds 0 and 1. We write $a + b$ for joins, $ab = a \cap b$ for meets. By $(a]$ and $[a)$ we denote principal ideals and filters. The principal reference for lattice theory is [6]. Concerning subgroup lattices see [4, 23].

Given L consider a lattice S and one-to-one maps σ and π of S into L which are join- resp. meet-preserving. If $\sigma x \leq \sigma y \leq \pi x$ for each covering pair $x \prec y$ in S and if

$$L = \bigcup_{x \in S} [\sigma x, \pi x]$$

then the structure of L can be recovered from the structure of S and of the blocks $L_x = [\sigma x, \pi x]$ and, of course, the maps σ and π - see [11, 7, 8]. We may require that σ is the identity map. In that case we speak of a decomposition of L into an S -glued sum and call S the skeleton and $\pi(S)$ the dual skeleton of this decomposition. If T is a sublattice of S , then $L_T = \bigcup_{x \in T} L_x$ is a sublattice of L . L_T is a T -glued sum if T is cover-preserving and an interval sublattice of L if T is one of S . The following is obvious.

LEMMA 1.1. *If the lattice L is the S -glued sum of the lattices L_x ($x \in S$) and φ_x ($x \in S$) are homomorphisms of L_x into L' with the property that φ_x coincides with φ_y on $L_x \cap L_y$ for all $x \prec y$ in S , then $\bigcup_{x \in S} \varphi_x$ is a homomorphism of L into L' .*

A coordinatization of a lattice L is given by a ring R , a left R -module M , and an isomorphism ω of L onto the lattice $L({}_R M)$ of all left R -submodules of M (we write $L(M)$ if no confusion is possible). It may be convenient to admit only faithful R -modules as we will do later on.

We say that an isomorphism φ from $L({}_R M)$ onto $L({}_S N)$ is (α -)semi-linearly induced (with respect to the isomorphism $\alpha : R \rightarrow S$) if there is an α -semi-linear isomorphism Φ of the R -module M onto the S -module N such that $\varphi(X) = \Phi(X)$ for all $X \in L({}_R M)$. If Φ is a semi-linear map, we denote the induced lattice map by $\hat{\Phi}$. If $R = S$ and α is the identity map, we speak of a linearly induced map. Observe that, if $\alpha : R \rightarrow S$ is a ring isomorphism, then $rx := \alpha(r)x$ turns any S -module ${}_S N$ into an R -module ${}_R N$ such that $L({}_S N) = L({}_R N)$. Moreover, $\Phi : {}_R M \rightarrow {}_S N$ is α -semi-linear if and only if $\Phi : {}_R M \rightarrow {}_R N$ is linear.

A local coordinatization of an S -glued sum L associates with each $x \in S$ a coordinatization R_x, M_x, ω_x of $L_x = [\sigma x, \pi x]$. The associated gluing maps are

$$\gamma_{xy} = \omega_y \circ \omega_x^{-1} : [\omega_x \sigma y]_{L(M_x)} \rightarrow (\omega_y \pi x)_{L(M_y)}.$$

Clearly,

$$\gamma_{yz} \circ \gamma_{xy} = \gamma_{wz} \circ \gamma_{xw} \quad \text{on } L_x \cap L_z \quad \text{for } x \prec y, w \prec z \text{ in } S.$$

We speak of a linear local coordinatization if $R_x = R$ for all x and all gluing maps are induced by linear isomorphisms

$$\Gamma_{xy} : M_x / (\omega_x \sigma y) \rightarrow \omega_y \pi x \subseteq M_y.$$

Given an S' -glued sum L' with linear local coordinatization R, M'_x, ω'_x and gluing maps γ'_{xy} a linear isomorphism of L onto L' is given by an isomorphism $\delta : S \rightarrow S'$ and linear isomorphisms

$$\Phi_x : M_x \rightarrow M'_{\delta x} \quad x \in S$$

such that

$$\hat{\Phi}_y \circ \gamma_{xy} = \gamma'_{\delta x \delta y} \circ \hat{\Phi}_x \quad \text{on } [\omega_x \sigma y] \quad \text{for } x \prec y \text{ in } S.$$

PROPOSITION 1.2. *Given the isomorphism $\delta : S \rightarrow S'$, the module isomorphisms $\Phi_x : M_x \rightarrow M'_{\delta x}$ constitute a linear isomorphism between linear local coordinatizations if and only if the lattice isomorphisms $\hat{\Phi}_x \circ \omega_x : L_x \rightarrow L(M'_{\delta x})$ constitute a linear local coordinatization of L .*

Proof. This is fairly trivial: since $\hat{\Gamma}_{xy} = \omega_y \circ \omega_x^{-1}$ we have

$$\hat{\Gamma}'_{\delta x \delta y} \circ \hat{\Phi}_x = \hat{\Phi}_y \circ \hat{\Gamma}_{xy} \quad \text{iff} \quad \hat{\Gamma}'_{\delta x \delta y} = \hat{\Phi}_y \circ \omega_y \circ (\hat{\Phi}_x \circ \omega_x)^{-1}. \quad \square$$

Also, we obtain isomorphisms

$$\omega'_{\delta x}{}^{-1} \circ \hat{\Phi}_x \circ \omega_x : L_x \rightarrow L'_{\delta x}.$$

From Lemma 1.1 it follows that a linear isomorphism between linear local coordinatizations induces a lattice isomorphism. Such a lattice isomorphism φ will be called *locally linear* if, in addition, σ and σ' are identity maps and $\delta = \varphi|_S$.

Decompositions into glued sums may be also viewed as *tolerances* θ (i.e. symmetric and reflexive binary relations compatible with the lattice operations) where $a \theta b$ if and only there is some block containing both a and b . Here, the additional requirement is that θ is *glued*, i.e. $a \theta b$ for each prime quotient. Conversely, every glued tolerance leads to a decomposition into a glued sum (see [2, 7]): For each $a \in L$ we have greatest a^θ and smallest a_θ such that $a \theta a^\theta$ and $a \theta a_\theta$. Then

$$b \leq a^\theta \quad \text{if and only if} \quad b_\theta \leq a$$

which means that the maps $x \mapsto x_\theta$ and $x \mapsto x^\theta$ form a pair of adjoints between L and its dual. In particular, they are join resp. meet preserving and S can be recovered as

$$S = \{x \in L \mid x = (x^\theta)_\theta\} = \{x_\theta \mid x \in L\}$$

while $\sigma x = x$ and $\pi x = x^\theta$. The blocks are recovered as the maximal intervals $[a, b]$ such that $a \theta b$. Moreover, each tolerance is determined by its set Q of quotients (the a/b with $a \theta b$) and these sets are characterized by the following properties and their duals (see [2]):

$$a/b \in Q, a \geq c \geq d \geq b \quad \text{implies} \quad c/d \in Q$$

$$a/b \in Q, c = a + d, b = a \cap d \quad \text{implies} \quad c/d \in Q$$

$$a/b, c/b \in Q \quad \text{implies} \quad (a + c)/b \in Q.$$

For modular lattices L of finite height a particular such decomposition is given by

$$b \theta a \quad \text{if and only if} \quad [a, b] \text{ is complemented}$$

for $a \leq b$. In this case $a^* := a^\theta$ is the join of a and all its upper covers in L so that a^* is the greatest element such that $[a, a^*]$ is complemented. a_* is defined,

dually, and subscript L is added, if necessary. We speak of the *prime skeleton* and *dual prime skeleton* of L and denote them by $S(L)$ and $S^*(L)$, respectively.

The *breadth* of a modular lattice is defined as the maximum number of independent elements in interval sublattice. It is easily seen (cf. [11]) that this is the maximal breadth (height) of blocks of the prime tolerance. Breadth 1 lattices are chains. Every breadth 2 modular lattice of finite height is Arguesian (cf. [12]).

2 Semi-primary lattices

An element c of a lattice L is called a *cycle* if $[c]$ is a chain, and a dual cycle if $[c]$ is a chain. If c is a cycle and L modular then $a + c$ is a cycle in $[a]$. If $c, d \in L$ are cycles and $c \leq d$, then c is called a *sub-cycle* of d . A cycle c is called a *k-cycle* or of *rank k* if $[c]$ is of height k . The unique k -sub-cycle of the cycle c will be denoted by c^k .

LEMMA 2.1. *In a modular lattice of finite height, if c is a rank k cycle and $c \leq \sum c_i$ with cycles c_i of rank k_i then $k \leq \max k_i$. If, in addition, the c_i are independent then $c \leq \sum c_i^k$.*

Proof. The proofs of Theorem 4.6 and Corollary 4.12 in [19] are valid for modular lattices of finite height, in general. \square

A lattice L is said to be *semi-primary* if L is of finite height, modular and every element of L is the join of cycles and the meet of dual cycles - see [19] from where we recall the most important facts. A semi-primary lattice is called *primary* if no elements have exactly two upper covers, equivalently, if all of its complemented intervals are irreducible. Every interval sublattice or dual of a semi-primary lattice is semi-primary.

Let L be a semi-primary lattice. For $a \in L$, the maximum rank of cycles $c \leq a$ is called the *rank* of a . The rank of L is defined as the rank of 1. By Lemma 2.1 it is the maximum of the ranks of the c_i if 1 is a join of cycles c_1, \dots, c_m .

LEMMA 2.2. [19] *If $\text{rank}(L) = r$ and $a \in L$ is an r -cycle, then a has a complement in L . In fact, for every element x of L with $a \cap x = 0$ there is a complement $a' \geq x$ of a .*

Every element a of L is the join of independent cycles ($\neq 0$) - and these form a *basis* of a . Indeed, every $\text{rank}(a)$ -sub-cycle of a can be completed to a basis of a . By Ore's Theorem, the basis elements are unique up to exchange isomorphism. In particular, a has a well defined *type* $\text{tp}(a) = (k_1, k_2, \dots, k_r)$ where r is the rank of a and k_i is the number of i -cycles in a basis of a and $m = \sum k_i$ is the number of basis elements. Usually, we will order the basis elements a_1, \dots, a_m such that the ranks $h_i = h(a_i)$ form a non-increasing sequence and will speak of an *ordered basis*. Accordingly, we may denote the type of a also by the sequence $[h_1, \dots, h_m]$.

The type $\text{tp}(L)$ of L is defined as the type of 1. A basis of 1 is also called a basis of L . If c_1, \dots, c_m is a basis of L , then the c_i^k are the join irreducibles in a sublattice which is isomorphic to the direct product of m chains of heights $h(c_i)$ and the elements of which are said to *fit* into the basis. For each such a one has the *induced basis* formed by the $a \cap c_i$. In particular, c_1^1, \dots, c_m^1 is a basis of (0^*) . Moreover, the $c'_i = \sum_{j \neq i} c_j$ form a basis of the dual lattice (said to be *dual* to the given basis) with the same fitting elements and $(c_i] \cong [c'_i)$. Thus, the type of a semi-primary lattice is equal to the type of its dual.

LEMMA 2.3. *Every atom or coatom fits into some basis.*

Proof. For an atom this means $a \leq c_j$ for some j . We proceed by induction on the height of L . Let c be a $\text{rank}(L)$ -cycle. If $a \leq c$ then we can consider any basis of L containing c . If $a \not\leq c$ then by Lemma 2.2 there exists a complement d of c with $a \leq d$. Now apply the inductive hypothesis for $(d]$ and add c to the basis of d so obtained. For a coatom we obtain a basis of the dual lattice and fit it into the dual of this basis. \square

Of course, behind the equivalence of the two concepts of type there is a bijective correspondence between finite non-increasing sequences $[h_1, \dots, h_m]$ of integers ≥ 1 and sequences (k_1, \dots, k_r) of integers ≥ 0 with $k_r \neq 0$ given by

$$r = h_1, \quad k_i = |\{j \mid h_j = i\}|, \quad h_j = \max\{s \mid j \leq \sum_{s \leq i} k_s\}.$$

Defining a partial order on sequences of the first kind by

$$[g_1, \dots, g_n] \leq [h_1, \dots, h_m] \text{ iff } n \leq m \text{ and } g_i \leq h_i \text{ for all } i \leq n$$

it translates to

$$(l_1, \dots, l_s) \leq (k_1, \dots, k_r) \text{ iff } s \leq r \text{ and } \sum_{i=t}^s l_i \leq \sum_{i=t}^r k_i \text{ for all } t \leq s.$$

Both ways we have the descending chain condition so that we may use order induction on types.

LEMMA 2.4. $\text{tp}(I) \leq \text{tp}(L)$ for every interval-sublattice I of a semi-primary lattice L . In particular, $\text{rank } I \leq \text{rank } L$.

Proof. Induction on the height of I . Consider $I = [a)$ with an atom a and choose a basis c_1, \dots, c_m of L such that $a \leq c_m$. Then the $c_i + a$ ($i < m$) together with c_m (if that is $\neq a$) form a basis of I and $\text{tp}(I) \leq \text{tp}(L)$. Dually, for $I = (b]$. \square

COROLLARY 2.5. *The breadth of L equals the size of a basis, i.e. $m = \sum_{i=1}^r k_i$.*

Proof. Consider a maximal number of independent elements in an interval $[a, b]$. Without loss of generality we may assume that these are atoms in $[a, b]$. Hence, their number is bounded by the size of a basis of $[a, b]$ and so of L . The converse is trivial. \square

The *geometric dimension* $\text{gd}(L)$ of a semi-primary lattice L is the maximal number of independent cycles of maximal rank. The *geometric rank* is the maximal n such that there are at least 3 independent n -cycles. In other words, n is maximal such that $\sum_{i=n}^r k_i \geq 3$. Rank and geometric rank coincide if and only if $\text{gd}(L) \geq 3$, i.e. $\text{tp}(L) = [n, n, n, \dots]$.

Given bases a_1, \dots, a_m of L and a'_1, \dots, a'_m of L' an isomorphism $\varphi : L \rightarrow L'$ is *basis preserving* if $\varphi(a_i) = a'_i$ for all i . It follows that $\varphi(a_i^h) = \varphi(a_i'^h)$ for all h .

3 Skeletons of semi-primary lattices

THEOREM 3.1. *A modular lattice L of finite height is semi-primary if and only if $S(L)$ and $S^*(L)$ are interval sublattices.*

COROLLARY 3.2. *Let L be a semi-primary lattice. If the type of L is (k_1, \dots, k_r) then the type of $S(L)$ is (k_2, \dots, k_r) , and the corresponding blocks are of type (m) where $m = \sum_{i=1}^r k_i$. More precisely, if a_1, \dots, a_m is a basis of L then the a_i^1 form a basis of the block (0^*) and the nonzero $a_i^{h(a_i)-1}$ form a basis of $S(L)$. Conversely, if the type of $S(L)$ is (h_1, \dots, h_l) and the type of the blocks is (m) then the type of L is $(m - \sum h_i, h_1, \dots, h_l)$.*

COROLLARY 3.3. *The prime skeleton of a semi-primary lattice consists of the elements which do not contain a maximal cycle.*

COROLLARY 3.4. *If a semi-primary lattice has a basis consisting of cycles of the same rank r then the maximal cycles are the rank r cycles.*

Proof. The corollaries will be proved at the end of the section. In the proof of the theorem we shall use of the fact that for $x \leq b \in L$ we have $x^{*(b)} = x^* \cap b$ and $x_{*(b)} = x_*$, and dually for ideals.

The ‘only if’ is in [9]. For convenience, a proof is included, here. We proceed by induction on the height of L . Let L be semi-primary. If $a \leq 1_*$ is an atom choose a basis c_1, \dots, c_m such that $a \leq c_1$. Since $c_1 \not\leq 1_*$ we have $a < c_1$ and a cycle d covering a . It follows $a = d_* \in S(L)$. Now, consider $b \leq 1_*$ minimal such that $b \notin S(L)$. Then b is join irreducible in L and $(b^*)_* = b_* > 0$. Choose an atom $a \leq b_*$. By inductive hypothesis we have $b \in S([a])$ whence $(b^*)_* = (b^*)_{*([a])} = b$, a contradiction.

Conversely, assume that $S(L)$ and $S^*(L)$ are intervals. Having a covering pair $x < y$ in $S(L)$ means that we have a covering $x \prec y$ in L (since $S(L)$ is an interval) and a covering $x^* < y^*$ in $S^*(L)$ (via the isomorphism) whence also

$x^* \prec y^*$ in L (since $S^*(L)$ is an interval). It follows that $[x, x^*]$ and $[y, y^*]$ are of the same height. Therefore, all blocks have the same height.

We claim that the prime skeleton and the dual prime skeleton are intervals of $[b]$ for every coatom b of L . Consider an element $a \in L$ such that $0^{*(b)} = 0^* \cap b \leq a \leq b$. By hypothesis $a + 0^* \in S^*(L)$ whence $a + 0^* = x^*$ with $x = (a + 0^*)_*$. Since $x = a_* + (0^*)_* = a_* < a$ we have $x^{*(b)} = x^* \cap b = (a + 0^*) \cap b = a$, that is, $a \in S^*((b))$. On the other hand let $a \leq b_*$. Since $b_* \leq 1_*$ we have $a \in S(L)$, by assumption. If $a^* \leq b$ then $a = (a^*)_* = (a^*)_{*(b)} \in S((b))$. Assume $a^* \not\leq b$ and $c_* \neq a$ where $c = b \cap a^* \prec a^*$. Then $c_* \prec a$ and $c = (c_*)^* \in S^*(L)$ since $[c_*, c]$ has the height of a block. By hypothesis one has $b \in S^*(L)$, too. Being a subinterval of a block, $[b_* \cap a^*, a^*]$ is complemented and so is, by modularity, $[b_*, b_* + a^*]$. Hence $b_* + a^* \leq (b_*)^* = b$, a contradiction.

In view of the inductive hypothesis we have that every join irreducible element $a < 1$ is a cycle. Finally, assume that 1 is join irreducible. Then $1_* \in S(L)$ has at most one lower cover b since $b \in S(L)$, $b^* < 1$, and so $b = 1_{**}$. In this case L is a chain. Thus, every element of L is a join of cycles. Meets are dealt with, dually.

Coming to the proof of the corollaries, recall that $(0^*]$ has type (m) with $m = \sum k_i$. Since for $b = \sum a_i^{h(a_i)-1}$ the filter $[b]$ has type (m) , too, we get $b = 1_*$. In the second corollary, if a is covered by the cycle c , then $a = c_* \in S(L)$. Thus, any element not containing a maximal cycle is a join of elements in $S(L)$ whence in $S(L)$. The converse is obvious from the type of $S(L)$. Finally, if $\text{rank } a_i = r$ for all i , then $c \leq \sum a_i^{r-1} = 1_*$ for every cycle c of rank $< r$ whence $c \in S(L)$ and c is not maximal. \square

4 Geometric decomposition

THEOREM 4.1. *For every integer l and semi-primary lattice L there is a glued tolerance $\theta = \theta_l$ such that for all $a \leq b$*

$$a \theta b \quad \text{if and only if} \quad \text{rank}[a, b] \leq l.$$

Given any basis a_1, \dots, a_m with $\text{rank } a_i = h_i$ the skeleton and dual skeleton are

$$S_\theta = \left(\sum a_i^{h_i-l} \right], \quad S^\theta = \left[\sum a_i^l \right).$$

The blocks are all of the same type

$$(k_1, \dots, k_{l-1}, k) \quad \text{with } k = \sum_{i=l}^r k_i, \quad (k_1, \dots, k_r) = \text{tp}(L).$$

Of course, we put $h - l := 0$ if $h < l$. One observes that for $L = L({}_R M)$ with a completely primary uniserial ring R (cf. Section 5) this tolerance θ is given by $X\theta Y$ if and only if $P^l X \subseteq Y$ and $P^l Y \subseteq X$ and that $X_\theta = P^l X$ and $X^\theta = \{x \in M \mid P^l x \subseteq X\}$.

Proof. Let L be a semi-primary lattice. By Lemmas 2.4 and 2.1 it is clear that θ is a tolerance. Let (k_1, \dots, k_r) be the type of L and let $m = \sum k_i$. Clearly, the indicated type of blocks is a bound on types of interval sublattices of rank $\leq l$. First, we establish a decomposition into a glued sum with the required skeletons and type of blocks. We do so by an iterated formation of prime skeletons.

Let $S^1(L) = S(L)$ and $S^{*1}(L) = S^*(L)$. For $j > 1$ let $S^j(L)$ be the prime skeleton of $S^{j-1}(L)$, and $S^{*j}(L)$ the dual prime skeleton of $S^{*j-1}(L)$. Observe that the isomorphism $x \mapsto x^{*L}$ of $S(L)$ onto $S^*(L)$ restricts to an isomorphism

$$* : S^{*j}(S(L)) \rightarrow S^{*j}(S^*(L)).$$

By recursion on j , we define isomorphisms

$$\varphi_j^L : S^j(L) \rightarrow S^{*j}(L).$$

Let $\varphi_1^L(x) = x^{*L}$. To define φ_{j+1}^L for $j > 1$, we compose

$$\varphi_j^{S(L)} : S^j(S(L)) \rightarrow S^{*j}(S(L))$$

with the above isomorphism, that is

$$\varphi_{j+1}^L(x) = \varphi_j^{S(L)}(x)^*.$$

Using induction on j , we prove that for any semi-primary lattice L , the identity map and the map φ_j^L provide a decomposition of L into a glued sum with skeleton $S^j(L)$. The case $j = 1$ is the classical decomposition into maximal complemented intervals. In the step from j to $j + 1$ we apply the inductive hypothesis to j and $S(L)$. This yields

$$x \leq \varphi_j^{S(L)}(x) \leq \varphi_j^{S(L)}(x)^* = \varphi_{j+1}^L(x) \quad \text{for } x \in S^{j+1}(L) \subseteq S^j(L).$$

Also, considering an element $a \in L$ we have $a \in [y, y^*]_L$ for some $y \in S(L)$ and $y \in [x, \varphi_j^{S(L)}(x)]_{S(L)}$ for some $x \in S^j(S(L))$. Then $x \leq y \leq a \leq y^* \leq \varphi_j^{S(L)}(x)^* = \varphi_{j+1}^L(x)$, that is $a \in [x, \varphi_{j+1}^L(x)]$. Finally, if $x \prec y$ in $S^{j+1}(L)$ then the same is true in $S^j(L)$ and

$$y \leq \varphi_j^{S(L)}(x) \leq \varphi_{j+1}^L(x).$$

By Corollary 3.2, the type of $S^j(L)$ is (k_{j+1}, \dots, k_r) . Using induction we show that the type of $[x, \varphi_j^L(x)]$ is $(k_1, \dots, k_{j-1}, \sum_{i=j}^r k_i)$. Let $x \in S^{j+1}(L)$. The type of $[x, \varphi_j^{S(L)}(x)]$ is $(k_2, \dots, k_j, \sum_{i=j+1}^r k_i)$ by the inductive hypothesis. Since $\varphi_j^{S(L)}(x) \in S(L)$ the interval $[\varphi_j^{S(L)}(x), \varphi_{j+1}^L(x)]$ is a maximal complemented one

even in L and of type $(\sum_{i=1}^r k_i)$. It follows that the interval $[x, \varphi_{j+1}^L(x)]$ has $\varphi_j^{S(L)}(x)$ as meet of its coatoms and $[x, \varphi_j^{S(L)}(x)]$ as its prime skeleton. Hence, by Corollary 3.2, its type is

$$\left(\sum_{i=1}^r k_i - \sum_{i=2}^r k_i, k_2, \dots, k_j, \sum_{i=j+1}^r k_j\right) = (k_1, k_2, \dots, k_j, \sum_{i=j+1}^r k_i).$$

Now, let $j = l$. Then the blocks are of rank l and of the claimed type. For any basis we have $u \in S^l(L)$ where $u = \sum a_i^{h_i-l}$. Since the height of u and $[u, \varphi_l u]$ add up to the height of L , we have that u is the greatest element of $S^l(L)$ - which is an ideal in view of Theorem 3.1. Moreover, if $x \leq u$ then $x \leq \varphi_l x \leq x^\theta$ since $\text{rank } [x, \varphi_l x] \leq l$. Hence $\varphi_l x = x^\theta \in S^\theta(L)$ and $x \in S_\theta(L)$ since $[x, \varphi_l x]$ is a maximal interval of rank $\leq l$. Conversely, consider $a \in S_\theta(L)$ i.e. $a = b_\theta$ for some b . Since we have a glued sum, there is an $x \leq u$ such that $x \leq b \leq x^\theta$. It follows $a = b_\theta \leq (x^\theta)_\theta = x \leq u$. This summarizes to $S_\theta(L) = (u)$. The claim about $S^\theta(L)$ follows by duality. \square

COROLLARY 4.2. *On each semi-primary lattice L of breadth ≥ 3 there is a glued tolerance having as blocks the maximal intervals of $\text{gd} \geq 3$, namely θ_n where n is the geometric rank of L . The skeleton $S_+(L)$ of θ_n is an ideal of L . $S_+(L)$ is a chain of height $h_1 - n$ if and only if L has geometric dimension 1. Otherwise, $S_+(L)$ is of breadth 2 and type $[h_1 - n, h_2 - n]$.*

Proof. We have $n = h_3$ and $h_1 > h_3$. Moreover, for u as in the proof of the theorem we have $u = a_1^{h_1-n} + a_2^{h_2-n}$ if $h_2 > h_3$ and $u = a_1^{h_1-n}$ if $h_2 = h_3$. \square

Let n be the geometric rank of the semi-primary lattice L . Skeleton and dual skeleton of L with respect to the tolerance θ_n are denoted by $S_+(L)$ and $S^+(L)$. We speak of the *geometric decomposition* and write $a^+ = a^\theta$ for the join of a and all cycles of rank $\leq n$ in $[a]$. We define a_+ , dually.

COROLLARY 4.3. *If $x \prec y$ in $S_+(L)$ then $[x, y^+]$ has rank $n + 1$ and for every cycle c of rank $n + 1$ in $[x, y^+]$ one has $c^1 = y$ and $c^n = c \cap x^+$.*

COROLLARY 4.4. *If u is a coatom of $S_+(L)$ then u is of one of the types below and there is an ordered basis a_1, \dots, a_m of L with h_i such that*

$$\begin{array}{lll} u = a_1^{h_1-n-1} & u^+ = a_1^{h_1-1} + \sum_{i>1} a_i & \text{if } \text{tp}(u) = [h_1 - n - 1], \\ u = a_1^{h_1-n-1} + a_2^{h_2-n} & u^+ = a_1^{h_1-1} + \sum_{i>1} a_i & \text{if } \text{tp}(u) = [h_1 - n - 1, h_2 - n], \\ u = a_1^{h_1-n} + a_2^{h_2-n-1} & u^+ = a_2^{h_2-1} + \sum_{i \neq 2} a_i & \text{if } \text{tp}(u) = [h_1 - n, h_2 - n - 1]. \end{array}$$

Proof. By Lemma 2.3 u fits into some basis of $S_+(L)$ hence it may have only one of the above types. u^+ is a coatom of L , hence by Lemma 2.3 it fits into some ordered basis. Since u^+ is a coatom of $S^+(L)$ it has the required form. Now, for $x = a_1^{h_1-n-1} + a_2^{h_2-n}$ the interval $[x, u^+]$ has the type of a block, whence $x = u$. \square

5 Completely primary uniserial rings

An (associative) ring R (with unit) is said to be *completely primary uniserial* (CPU for short) if there is a two sided ideal P of R such that every left ideal as well as every right ideal of R is of the form P^k (where $P^0 = R$) - cf. [19]. The *rank* of such a ring is the smallest integer n such that $P^n = \{0\}$. Particular commutative examples are the rings A/Ap^n where A is a principal ideal domain and p a prime. The following basic properties of CPU rings can be easily verified.

1. There exists an element $a \in R$ such that $P = aR = Ra$.
2. $P^i = a^i R = Ra^i$.
3. $a^{n-1} \neq 0$, $a^n = 0$.
4. r is left, equivalently right, invertible if and only if $r \in R^* = R \setminus P$.
5. Every element $r \in R$ is of the form $r = a^i u = va^i$ where u and v are units, $0 \leq i \leq n$ such that $r \in P^i \setminus P^{i+1}$.
6. $1 - a \in R^*$ and R is generated by R^* .

COROLLARY 5.1. *Let R be a CPU ring of rank n with maximal ideal P . Then for any cyclic left R -module, $L({}_R M)$ is a chain of height $\leq n$ and two such modules are isomorphic if and only if they have the same height. In particular, the left R -modules P^{m-i}/P^{n-i} and P^m are isomorphic for $m \geq i$.*

Proof. The multiplication by a^i on the right is a homomorphism of P^{m-i} onto P^m with kernel P^{n-i} . □

THEOREM 5.2. *If R is a CPU ring then for every $k \geq \text{rank } R$ there exists a CPU ring S of rank k such that R is a homomorphic image of S .*

Proof. Let R be a CPU ring of rank n with maximal ideal Ra . Clearly, it suffices to consider $k = n + 1$. If $n = 1$ then R is a division ring and we may use $S = R[x]/(x^2)$ where x is a commuting variable.

So let $n \geq 2$. We first construct a homomorphic preimage F of the envisioned ring S . Let M be the free monoid with x and the elements of the unit group R^* as generators and the following relations

$$\begin{aligned} uv &= w \text{ if that is the case in } R^*, \\ ux &= xv \text{ if } va = au \text{ in } R \text{ with } u, v \in R^*. \end{aligned}$$

Then there is a homomorphism Φ of M into R with $\Phi x = a$ and $\Phi u = u$ for $u \in R^*$ so that R^* may be considered a sub-monoid of M . Moreover, the free monoid on one generator x is obtained as a homomorphic image mapping x to x and all generators $u \in R^*$ to 1. Hence,

$$x^k u = x^l v \text{ with } u, v \in R^* \text{ implies } k = l.$$

Moreover, each element of M has a representation $vx^k = x^k u$ with $u, v \in R^*$ and $k \geq 0$ since these elements form a sub-monoid due to the required relations.

Now, let $F = \mathbb{Z}[M]$ the free ring over this monoid, i.e. each element of F has a representation

$$\sum_i z_i x^{k_i} u_i = \sum_i x^{k_i} z_i u_i \quad \text{with } u_i \in R^* \text{ and } z_i \in \mathbb{Z}.$$

Here, we may require the $x^{k_i} u_i$ to be pairwise distinct and the $z_i \neq 0$; under this proviso, the $x^{k_i} u_i$ are unique up to permutation and for each $x^{k_i} u_i$ the associated coefficient z_i is uniquely determined. $\mathbb{Z}(R^*)$ is the subring of F consisting of the elements $\sum_i z_i u_i$ with $u_i \in R^*$, $z_i \in \mathbb{Z}$ and

$$x^k F = \bigcup_{l=k}^{\infty} x^l \mathbb{Z}(R^*).$$

By the defining relations, the $u \in R^*$ are units in F . Also, using in addition the commutation relations

$$vu = uvv^{-1}u^{-1}vu \quad \text{for } u, v \in R^*$$

we see that $Fr \subseteq rF$ for all $r \in F$. Since $rF \subseteq Fr$, too, we have

$$rF = Fr \quad \text{for all } r \in F$$

and every left or right ideal is an ideal. In particular, every maximal ideal Q of F is maximal both as left and right ideal whence F/Q is a division ring and Q a prime ideal of F .

Clearly, Φ extends to a ring homomorphism from F onto R . Let I be the kernel of Φ and $P = \Phi^{-1}(Ra)$, in particular $x \in P$. Then P is a maximal ideal of F and $P^n \subseteq I \subseteq P$. Also, $Q = P \cap \mathbb{Z}(R^*)$ is an ideal of $\mathbb{Z}(R^*)$ and

$$x^k FQ = \bigcup_{l=k}^{\infty} x^l Q.$$

Now, consider $q = \sum_i z_i u_i \in Q$. There are $v_i \in R^*$ such that $u_i x = x v_i$ and we have $r = \sum_i z_i v_i \in \mathbb{Z}(R^*)$. Of course, $xr = qx$ and $a\Phi(r) = \Phi(q)a \in a^2 R$. It follows $\Phi(r) \notin R^*$ whence $r \in Q$. This shows $Qx \subseteq xQ$. Similarly, $xQ \subseteq Qx$ whence

$$Qx = xQ \quad \text{and} \quad QF = FQ.$$

Since $x \in P$ we have $P = xF + Q$ and it follows

$$P^l = x^l F + \sum_{k < l} x^k Q.$$

Now, assume $x^n \in P^{n+1}$. Then we have

$$x^n = x^{n+1}r + \sum_{k \leq n} x^k q_k = \sum_j x^{n+1+k_j} z_j u_j + \sum_{k,i} x^k z_{ki} u_{ki}$$

with $z_j, z_{ki} \in \mathbb{Z}$, $u_j, u_{ki} \in R^*$ and $q_k = \sum_i z_{ki} u_{ki} \in P$ for all $k \leq n$. We may assume that $u_{n1} = 1$ and that all $x^{n+1+k_j} u_j$ pairwise distinct as well as, for fixed k , all $x^k u_{ki}$. Then all these elements of M are pairwise distinct and from the uniqueness of the representation we conclude $z_{n1} = 1$ and $z_j = z_{ki} = 0$, otherwise. This yields $1 = q_n \in P$, a contradiction.

Now, assuming $I = PI$ one has $I \subseteq P^k$ for all k and $P^n = P^{n+1}$ contradicting $x^n \in P^n \setminus P^{n+1}$. Thus, $PI \neq I$ and we may choose $y \in I \setminus PI$. By Zorn's Lemma there is an ideal $J \supseteq PI$ maximal with $y \notin J$ and J has a unique upper cover J^* in the ideal lattice. Now $J \subseteq P$ since $J \neq F$ and $P^{n+1} \subseteq J$ and P maximal (choose a maximal ideal $Q \supseteq J \supseteq P^{n+1}$, then $P \subseteq Q$ since Q is prime and $P = Q$ since P is maximal). Now, H/PH with $H = I + J$ is a left R/P -vector space. Consequently, the interval $[PH, H]$ of the ideal lattice is complemented (recall that left ideals are ideals) and so is the subinterval $[J, I + J]$. Hence there is a complement K of J^* in $[J, I + J]$ which is a coatom in this interval. In particular $J = K \cap J^*$ whence $y \notin K$ and $K = J$ by the maximality of J . It follows that J is a lower cover of $I + J$. Then $S = F/(I \cap J)$ is Artinian of height $n + 1$. Let us pass to this ring using the same names for the corresponding ideals. In particular, we have the unique maximal ideal P with $P^{n+1} = 0$ and $0 \neq P^n \subseteq I$. Also, I is a minimal ideal. Hence $I = P^n$ and the filter $[I]$ in the ideal lattice consists exactly of the $P^k, k \leq n$, since $S/I \cong R$ is CPU of rank n . Now, consider any ideal $H \not\supseteq I$. Then $I \cap H = 0$ and $I + H = P^k$ for some $k \leq n$ and $P^{k+1} = PI + PH \subseteq H$ whence $k = n$ and $H = 0$. Thus, S is a CPU ring of rank $n + 1$ and $S/I \cong R$. \square

6 Submodule lattices

A modular lattice L is *Arguesian* if

$$(A_0 + B_0) \cap (A_1 + B_1) \leq A_2 + B_2 \quad \text{implies} \quad C_2 \leq C_0 + C_1$$

for all $A_i, B_i \in L$ ($i = 0, 1, 2$) where $\{i, j, k\} = \{0, 1, 2\}$ and

$$C_i = (A_j + A_k) \cap (B_j + B_k).$$

In geometric terms: central perspectivity implies axial perspectivity. Every lattice $L({}_R M)$ of submodules is Arguesian. If R is a CPU ring and ${}_R M$ is finitely generated, then $L({}_R M)$ is also primary. Lattices isomorphic to such shall be called *coordinatizable*. The main result in [19] is the following.

THEOREM 6.1. *Every primary Arguesian lattice of geometric dimension ≥ 3 is coordinatizable.*

We collect some more facts about finitely generated modules ${}_R M$ over a CPU ring R and their lattices $L = L({}_R M)$. The ring R can be chosen so that ${}_R M$ is faithful - only such will be considered in the sequel. Then the rank of R is $n = \text{rank } L$. If Re_0, \dots, Re_{m-1} form a basis of L , i.e. if

$$M = \bigoplus_{i=0}^{m-1} Re_i$$

then e_0, \dots, e_{m-1} will be called a basis of ${}_R M$ and the e_0, \dots, e_{m-1} with the relations $a^{h_i} e_i = 0$ yield a presentation of ${}_R M$ where $P = Ra$ is the maximal ideal of R and $h_i = h(Re_i)$ - but observe that

$$re_i = 0 \text{ implies } r = 0 \text{ if and only if } h(Re_i) = n.$$

If $h_i \geq h_j$ for $i \leq j$ then we have an *ordered basis*. The type of L will be also called the *type* of ${}_R M$. Viewing ${}_R M$ and ${}_S N$ as 2-sorted structures one gets that for ${}_R M$ and ${}_S N$ of the same type, isomorphism $\alpha : R \rightarrow S$, and all ordered bases e_0, \dots, e_{m-1} of ${}_R M$ and f_0, \dots, f_{m-1} of ${}_S N$ there is a uniquely determined α -semi-linear bijection $\Phi : {}_R M \rightarrow {}_S N$ such that

$$\Phi(e_i) = f_i \quad \text{for } i = 0, \dots, m-1.$$

Given a basis e_0, \dots, e_{m-1} such that $h(e_0) = n$ and $a \in R$ such that Ra is the maximal ideal of R , we have the *canonical semi-frame* in L (cf. [18]) consisting of the

$$E_i = Re_i \ (0 \leq i < m) \text{ and } E_{0i} \ (1 \leq i < m), \quad \text{where } E_{ij} = R(e_i + e_j).$$

In particular, if $h_i = n$ for $i \leq l$ then the E_i and E_{0i} ($i \leq l$) generate a frame of order l in the sense of von Neumann (cf. [13]).

COROLLARY 6.2. *The automorphism group of ${}_R M$ acts transitively on the set of semi-frames associated with ordered bases.*

We say that X is an *axis* for Y and Z in L if

$$X \oplus Y = Y \oplus Z \quad \text{and} \quad X + Z \geq Y.$$

Observe that this concept is not symmetric in Y and Z .

LEMMA 6.3. *Let $h(Re_i) \geq h(Re_j)$. Then $X = R(e_i + re_j)$ for some $r \in R$ if and only if X is a complement of Re_j in the ideal $(Re_i + Re_j]$ of L and $r \in R^*$ if and only if X is an axis for Re_i, Re_j . If $h(Re_i) = n$ then r is uniquely determined.*

Proof. Such complement X is cyclic since $X \cong Re_i$. Hence $X = R(a^k e_i + re_j)$ for some k and r . If $k > 0$ then $X + Re_j = Ra^k e_i + Re_j < Re_i + Re_j$. Thus, $k = 0$. Now, $r = a^k s$ with some k and $s \in R^*$ and $X + Re_i < Re_i + Re_j$ if $k > 0$. Therefore $r \in R^*$ if X is an axis. The converse claims are obvious. Finally, $R(e_i + re_j) = R(e_i + se_j)$ implies $e_i + re_j = x(e_i + se_j)$ for some x whence $x = 1$ and $r = s$ if $h(Re_i) = n$. \square

Define the *coordinate domain*

$$R_{ij} = \{R(e_i + re_j) \mid r \in R\}.$$

LEMMA 6.4. L is generated by the canonical semi-frame together with $R_{01} \cup R_{10}$ resp. R_{01} provided that $h_0 = h_1 = \text{rank } L$ resp. also $h_2 = \text{rank } L$.

Proof. We proceed by induction on $n = \text{rank } L$. Assume that the basis is ordered with l maximal such that $h_l = n$. Let K be the sublattice generated by $R_{01} \cup R_{10}$ and the canonical semi-frame. First, observe that 0 and 1 may be interchanged since

$$E_{1i} = R(e_1 + e_i) = (R(-e_0 + e_1) + E_{0i}) \cap (E_1 + E_i) \quad \text{for } i > 1.$$

Moreover, any k with $1 < k \leq l$ may take the role of 1 since

$$R(e_0 + re_k) = (R(e_0 - re_1) + E_{1k}) \cap (E_0 + E_k) \in K.$$

Further elements of K are

$$Rre_1 = (R(e_0 + re_1) + E_0) \cap E_1, \quad Rre_i = (Rre_1 + E_{1i}) \cap E_i$$

$$R(ae_0 + e_i) = (R(-ae_0 + e_1) + E_{1i}) \cap (E_0 + E_i)$$

$$Rr(e_i + e_j) = E_{ij} \cap (Rre_i + E_j) \quad \text{for } i \leq l$$

$R(ae_h + rae_j) = (Rae_h + Rae_j) \cap R(e_h + se_j)$ for $\{h, j\} = \{0, 1\}$ where $ra = as$.

From these we obtain the canonical semi-frame and coordinate domains associated with the basis $ae_0, \dots, ae_l, e_{l+1}, \dots, e_{m-1}$ of the R/P^{n-1} -module

$$U = \sum_{j \leq l} Rae_j + \sum_{j > l} Re_j.$$

Since the R/P^{n-1} -submodules of U are just the R -submodules of U we have all of them in K , by induction. On the other hand, considering a cyclic submodule $X = R \sum_j r_j e_j$ of ${}_R M$ not in $(U]$, we have r_j invertible for some $j \leq l$ and may assume $j = 0$ and $r_0 = -1$. Then

$$X = \bigcap_{j > 0} (R(e_0 - r_j e_j) + \sum_{k \neq 0, j} Re_k) \in K.$$

Since any element of L is a join of cyclic submodules, we are done. \square

COROLLARY 6.5. *Let $\varphi : L({}_R M) \rightarrow L({}_S N)$ be a lattice isomorphism matching the canonical semi-frames associated with ordered bases e_0, \dots, e_{m-1} of ${}_R M$ and f_0, \dots, f_{m-1} of ${}_S N$. Assume that there are isomorphisms $\alpha, \beta : R \rightarrow S$ such that $\varphi(R(e_0 + re_1)) = S(f_0 + \alpha(r)f_1)$ and $\varphi(R(re_0 + e_1)) = S(\beta(r)f_0 + f_1)$ for all $r \in R$. If $\text{gd}(L({}_R M)) \geq 2$ then $\alpha = \beta$ and $\varphi = \hat{\Phi}$ for the α -semi-linear bijection $\Phi : {}_R M \rightarrow {}_S N$ such that $\Phi(e_i) = f_i$ for all i .*

Proof. If $r \in R^*$ then $S(f_0 + \beta(r)^{-1}f_1) = S(\beta(r)f_0 + f_1) = \varphi(R(re_0 + e_1)) = \varphi(R(e_0 + r^{-1}e_1)) = S(f_0 + \alpha(r^{-1})f_1)$ whence $\beta(r)^{-1} = \alpha(r^{-1})$ and $\alpha(r) = \beta(r)$ and $\alpha = \beta$ since R is generated by R^* . Thus $\hat{\Phi} = \varphi$ on the generators of $L({}_R M)$, whence everywhere. \square

COROLLARY 6.6. *Every isomorphism between lattices $L({}_R M)$ and $L({}_S M)$ as above of $\text{gd} \geq 3$ is semi-linearly induced.*

Proof. (cf. [5]) Following von Neumann (cf. [13]), R may be identified with any of the coordinate domains R_{ij} ($i, j \leq l$) the operations given in terms of the frame. The same holds for S so we get the isomorphisms α and β . \square

In particular, for such lattices we may call R *the coordinate ring*.

7 2-gluings

We now consider local coordinatizations R_x, M_x, ω_x , $x \in S_+(L)$ associated with the geometric decomposition of a primary Arguesian lattice L of breadth $m \geq 3$. Recall that all L_x are of the same type, of breadth m , $\text{gd} \geq 3$, and of rank n , where n is the geometric rank of L . The ring R_x has to be a coordinate ring of L_x . We say that a basis e_0, \dots, e_{m-1} of ${}_x M_x$ is *associated* with the basis b_0, \dots, b_{m-1} of L_x (via the given coordinatization) if

$$\omega_x(b_i) = R_x e_i \quad \text{for all } i.$$

First, we deal with the special case where $S_+(L) = \{0, \top\} \cong \mathbf{2}$, the two element lattice. We write $R = R_0$, $S = R_\top$, and $\gamma = \gamma_{0\top}$. We denote the elements of L by the corresponding submodules of M_0 resp. M_\top with a double notation $X = \gamma X$ for elements in $L_0 \cap L_\top$.

Consider a basis b_0, \dots, b_{m-1} of L with ranks h_i . In view of Corollary 4.2, we may arrange it such that $h_2 - 1 = h_0 = h_1 = n$ (this ordering fits better to the applications of the Arguesian law). We say that a basis e_0, \dots, e_{m-1} of ${}_R M_0$ associated with b_0, b_1, b_2^n, \dots and basis f_0, \dots, f_{m-1} of ${}_S M_\top$ associated with $\top + b_0, \dots, \top + b_{m-1}$ form a *pair of bases associated with* b_0, \dots, b_{m-1} , i.e. one has

$$b_i = R e_i, \quad \top + b_i = S f_i = R e_i + P^{n-1} e_2 \quad \text{for } i \neq 2, \quad b_2 = S f_2, \quad b_2^n = R e_2 = Q f_2$$

where P and Q are the maximal ideals of R and S , respectively. We call such a pair *b-synchronized* if $Sb = Q$, and if (cf. Fig.1.)

$$R(e_0 + e_i) + P^{n-1}e_2 = S(f_0 + f_i) \quad \text{for } i \neq 2$$

$$R(e_0 + e_2) + P^{n-1}e_2 = S(f_0 + bf_2).$$

Observe that the ordering matters.

THEOREM 7.1. *Let L be a primary Arguesian lattice of breadth ≥ 3 with $S_+(L) \cong \mathbf{2}$. Then for every local coordinatization $\omega_x : L_x \rightarrow L_{(R_x M_x)}$, ($x = 0, \top$), basis b_0, \dots, b_{m-1} of L such that $h(b_0) = h(b_1) = h(b_2) - 1 = \text{rank } L$, basis e_0, \dots, e_{m-1} of M_0 associated with b_0, b_1, b_2^n, \dots and generator b of the maximal ideals of $S = R_\top$ there is a basis f_0, \dots, f_{m-1} of M_\top yielding a *b-synchronized* pair of bases associated with b_0, \dots, b_{m-1} . Given such, there is a unique isomorphism $\alpha : R = R_0 \rightarrow S$ such that for the gluing map $\gamma = \gamma_{0\top}$*

$$\gamma(R(e_0 + re_1) + P^{n-1}e_2) = S(f_0 + \alpha(r)f_1).$$

Moreover, with this α one has $\gamma = \hat{\Phi}$ where Φ is the α -semi-linear map from ${}_R M_0 / (P^{n-1}e_2)$ into ${}_S M_\top$ such that

$$\Phi(e_i + P^{n-1}e_2) = f_i \quad \text{for } i \neq 2, \quad \Phi(e_2 + P^{n-1}e_2) = bf_2.$$

A *b-synchronized* pair of bases associated with a basis of L is *strictly b-synchronized* if $R = S$ and if α in the Theorem is the identity map.

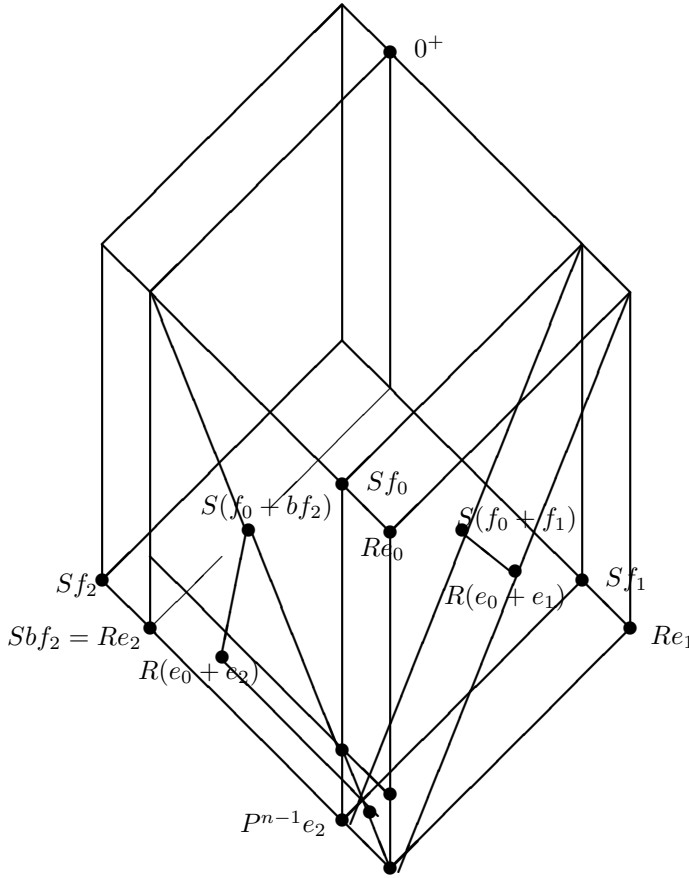

Figure 1.

COROLLARY 7.2. *For L as in the theorem, every coordinatization of L_0 may be completed to a linear local coordinatization of L . Given such, there is an automorphism Ψ_\top of ${}_R M_\top$ such that for the local coordinatization ω_0 , $\hat{\Psi}_\top \circ \omega_\top$ the e_i and f_i form a strictly b -synchronized pair.*

COROLLARY 7.3. *Let L and L' be primary Arguesian lattices of breadth ≥ 3 of the same type, with $S_+(L) \cong \mathbf{2} \cong S_+(L')$, and with linear local coordinatizations over the same ring. Let c and c' be cycles of maximal rank $n + 1$ in L resp. L' . Then every linear isomorphism Φ_0 of M_0 onto M'_0 such that $\hat{\Phi}_0 \omega_0 c^n = \omega'_0 c'^n$ can be extended to a linear isomorphism of the local coordinatizations such that $\hat{\Phi}_\top \omega_\top c = \omega'_\top c'$.*

COROLLARY 7.4. *In a primary Arguesian lattice L of breadth ≥ 3 the maximal intervals of $\mathbf{gd} \geq 3$ have isomorphic coordinate rings and are isomorphic. The gluing maps are semi-linearly induced.*

These rings are called the *coordinate rings* of L .

Proof. Choose the basis f_0, \dots, f_{m-1} to obtain a pair of bases associated with the given basis of L . Now $R(e_0 + e_i) + P^{n-1}e_2$ is a axis for $Re_0 + P^{n-1}e_2$ and $Re_i + P^{n-1}e_2$ in the filter $[P^{n-1}e_2)$ of $L(RM_0)$ and, via the gluing map, an axis for Sf_0 and Sf_i (resp. Sbf_2 if $i = 2$) in $L(SM_\top)$. Thus, by Lemma 6.3 there are $s_i \in S^*$ such

$$R(e_0+e_i)+P^{n-1}e_2 = S(f_0+s_i f_i) \quad \text{for } i \neq 0, 2 \quad R(e_0+e_2)+P^{n-1}e_2 = S(f_0+bs_2 f_2).$$

To carry out the synchronization, replace f_i by $s_i f_i$ for $i \neq 0$.

Now, assume that a b -synchronized local coordinatization is given. $R(e_0 + re_1) + P^{n-1}e_2$ is a complement of $Re_1 + P^{n-1}e_2$ in the interval $[P^{n-1}e_2, Re_0 + Re_1 + P^{n-1}e_2]$ which corresponds via the gluing map to Sf_1 in the ideal $(Sf_0 + Sf_1)$ of $L(SM_\top)$. Hence, by Lemma 6.3 there is a unique $\alpha(r) \in S$ such that

$$R(e_0 + re_1) + P^{n-1}e_2 = S(f_0 + \alpha(r)f_1).$$

We have $\alpha(0) = 0$ and $\alpha(1) = 1$. We have to show that α is an isomorphism. In doing so, we may consider the ideal $(b_0 + b_1 + b_2)$ of L which amounts to assuming $m = 3$. We proceed as in the proof of Theorem 2.1 of [8]. The calculations are by basic linear algebra as long as they are done within a single one of L_0 or L_\top . Yet, the passage from L_0 to L_\top via the gluing can be calculated only for the sublattice generated by the $Re_i + P^{n-1}e_2$, $R(e_0 + re_1) + P^{n-1}e_2$ and $R(e_0 + e_2) + P^{n-1}e_2$. To show compatibility with addition, let $r, s \in R$ and consider

$$A_0 = Re_1, \quad A_1 = R(e_0 + r(e_1 + e_2)), \quad A_2 = S(f_0 + \alpha(r)(f_1 + f_2))$$

$$B_0 = R(e_0 + se_1), \quad B_1 = R(e_1 + e_2), \quad B_2 = S(f_1 + f_2).$$

Then

$$(A_0 + B_0) \cap (A_1 + B_1) = Re_0 \leq S(f_0) + S(f_1 + f_2) = A_2 + B_2$$

$$C_2 = (A_0 + A_1) \cap (B_0 + B_1) = R(e_0 + (r + s)e_1 + re_2)$$

$$C_1 = (Sf_1 + A_2) \cap (S(f_0 + \alpha(s)f_1) + B_2) = S(f_0 + (\alpha(r) + \alpha(s))f_1 + \alpha(r)f_2)$$

$$A_1 + A_2 \leq R(e_0 + re_1) + Re_2 + A_2 \leq S(f_0 + \alpha(r)f_1) + Sf_2 + A_2 = S(f_0 + \alpha(r)f_1) + Sf_2$$

$$B_1 + B_2 \leq Re_1 + Re_2 + B_2 \leq Sf_1 + Sf_2 + B_2 = Sf_1 + Sf_2$$

$$C_0 \leq (S(f_0 + \alpha(r)f_1) + Sf_2) \cap (Sf_1 + Sf_2) = Sf_2.$$

From the Arguesian law we get

$$\begin{aligned} S(f_0 + \alpha(r + s)f_1) + Sf_2 &= C_2 + Sf_2 \\ &\leq C_0 + C_1 + Sf_2 \leq C_1 + Sf_2 = S(f_0 + (\alpha(r) + \alpha(s))f_1) + Sf_2 \end{aligned}$$

implying

$$f_0 + \alpha(r+s)f_1 = x(f_0 + (\alpha(r) + \alpha(s))f_1)$$

for some $x \in S$ and $\alpha(r+s) = \alpha(r) + \alpha(s)$.

Concerning multiplication consider

$$A_0 = Re_1, \quad A_1 = R(e_0 + re_1 + (1-r)e_2), \quad A_2 = S(f_0 + \alpha(r)f_1 + (1-\alpha(r))f_2)$$

$$B_0 = R(e_0 + se_1), \quad B_1 = R(e_0 + e_2), \quad B_2 = S(f_0 + f_2).$$

Then

$$(A_0 + B_0) \cap (A_1 + B_1) = Rr(e_0 + e_1) = (Re_0 + R(e_0 + re_1)) \cap R(e_0 + e_1)$$

$$\leq S\alpha(r)(f_1 - f_2) + S(f_0 + f_2) = A_2 + B_2$$

$$C_2 = R(e_0 + rse_1 + (1-r)e_2)$$

$$C_1 = (Sf_1 + A_2) \cap (S(f_0 + \alpha(s)f_1) + B_2) = S(f_0 + \alpha(r)\alpha(s)f_1 + (1-\alpha(r))f_2).$$

Let $I = \{x \in S \mid x\alpha(r) = 0\}$. Then

$$C_0 \leq (A_1 + Sf_2 + A_2) \cap (B_1 + Sf_2 + B_2) = (S(f_0 + \alpha(r)f_1) + Sf_2) \cap (Sf_0 + Sf_2) = If_0 + Sf_2.$$

By the Arguesian law

$$S(f_0 + \alpha(rs)f_1) + Sf_2 = C_2 + Sf_2 \leq C_0 + C_1 + Sf_2 \leq If_0 + Sf_2 + S(f_0 + \alpha(r)\alpha(s)f_1)$$

Hence there are $x, y \in S$ such that

$$f_0 + \alpha(rs)f_1 = xf_0 + y(f_0 + \alpha(r)\alpha(s)f_1) \quad \text{and} \quad x \cdot \alpha(r) = 0$$

Then

$$x + y = 1, \quad \alpha(rs) = y \cdot \alpha(r)\alpha(s) = (1-x)\alpha(r)\alpha(s) = \alpha(r)\alpha(s).$$

We now claim that e_1, e_0, e_2, \dots and f_1, f_0, f_2, \dots form a b -synchronized pair associated with the basis b_1, b_0, b_2, \dots . We use the isomorphism

$$\Psi : Rae_2 + \sum_{i \neq 2} Re_i \rightarrow M_0/P^{n-1}e_2, \quad \Psi(e_i) = e_i + P^{n-1}e_2, \quad \Psi(ae_2) = e_2 + P^{n-1}e_2$$

where $P = Ra$ (cf. Corollary 5.1). Now, for $i > 2$

$$R(e_1 + e_i) + P^{n-1}e_2 = \hat{\Psi}((R(e_0 - e_1) + R(e_0 + e_i)) \cap (Re_1 + Re_i))$$

$$= (S(f_0 - f_1) + S(f_0 + f_i)) \cap (Sf_1 + Sf_i) = S(f_1 + f_i)$$

$$R(e_1 + e_2) + P^{n-1}e_2 = \hat{\Psi}(R(e_1 + ae_2)) = \hat{\Psi}((R(e_0 - e_1) + R(e_0 + ae_2)) \cap (Re_1 + Rae_2))$$

$$= (S(f_0 - f_1) + S(f_0 + bf_2)) \cap (Sf_1 + Sbf_2) = S(f_1 + f_2).$$

Hence, we also get an isomorphism β as required in Corollary 6.5 and may conclude that γ is linearly induced by Φ . \square

Proof of the Corollaries. To obtain a linear local coordinatization of L turn ${}_S M_\top$ into an R -module via α . Now, assume that we start with a linear local coordinatization, the gluing map being induced by the linear map Γ . Theorem 7.1 provides us with α and a -synchronizing f_i . By Lemma 6.3 we have $s_i \in R^*$ such that

$$\Gamma(e_i + P^{n-1}e_2) = s_i f_i \text{ for } i \neq 2, \quad \Gamma(e_2 + P^{n-1}e_2) = s_2 a f_2.$$

Let Ψ_\top be the automorphism of the R -module M_\top such that

$$\Psi_\top(f_i) = s_i^{-1} f_i \quad \text{for all } i.$$

Now, let local coordinatizations M_x, ω_x of L and M'_x, ω'_x of L' be given, all over the same ring R , and an isomorphism $\Phi_0 : M_0 \rightarrow M'_0$. Complete $c = b_2$ to a basis of L such that $h(b_0) = h(b_1) = n$. Then $b'_2 = c'$ and the $b'_j = \omega_0'^{-1} \hat{\Phi}_0 \omega_0(b_j)$ form a basis of L' with $h(b'_0) = h(b'_1) = n$ since $\omega_0'^{-1} \hat{\Phi}_0 \omega_0(b_2^n) = c'^n$. Choose bases e_i of M_0 , f_i of M_\top and Ψ_\top according to Corollary 7.2. Analogously, choose bases e'_i of M'_0 , f'_i of M'_\top and Ψ'_\top . Now, let $\Theta : M_\top \rightarrow M'_\top$ be the isomorphism such that $\Theta(f_i) = f'_i$ and $\Phi_\top = \Psi_\top'^{-1} \circ \Theta \circ \Psi_\top$. Then

$$\hat{\Phi}_\top \omega_\top(b_2) = \hat{\Psi}_\top'^{-1} \hat{\Theta} \hat{\Psi}_\top \omega_\top(b_2) = \hat{\Psi}_\top'^{-1} \hat{\Theta}(Rf_2) = \hat{\Psi}_\top'^{-1}(Rf'_2) = \omega_\top'(b'_2). \quad \square$$

8 2×2 -gluings

THEOREM 8.1. *Let L be a primary Arguesian lattice of breadth ≥ 3 and $S \cong 2 \times 2$ a cover preserving sublattice of $S_+(L)$ with atom v and with $0 \in S$. Then a local coordinatization of $L_S = \cup_{x \in S} L_x$ over a single ring R is linear provided that all gluing maps γ_{xy} with $y \neq v$ are linearly induced.*

COROLLARY 8.2. *Let L, S and L', S' as in the Theorem with local coordinatizations of L_S and $L'_{S'}$, given by M_x and M'_x over the same R . Let v be an atom of S . Then isomorphisms $\delta : S \rightarrow S'$ and $\Phi_x : M_x \rightarrow M'_x$ yield a linear isomorphism provided they do so if one considers the sublattices $S \setminus \{v\}$ and $\{0, v\}$, only.*

COROLLARY 8.3. *Every primary Arguesian lattice of breadth ≥ 3 admits a linear local coordinatization (over any of its coordinate rings)*

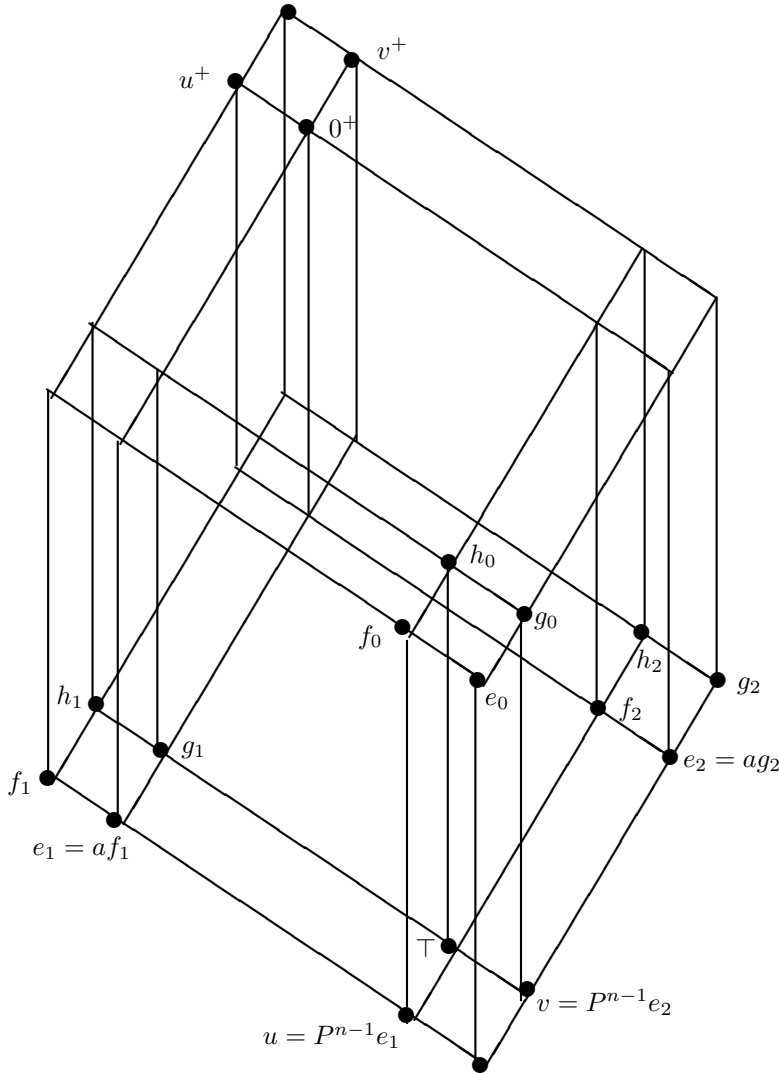

Figure 2.

Proof. Let us denote the atoms of S by u, v and let $\top = u + v$. Choose cycles $a_1 \in L_u$ and $a_2 \in L_v$ of rank $n + 1$ where n is the geometric rank of the L . Then $a_1^1 = u \neq v = a_2^1$ and we may complete to a basis a_0, \dots, a_{m-1} of L with $h(a_0) = n$. Now assume that a local coordinatization $\omega_x : L_x \rightarrow L(RM_x)$ of L_S over the same ring R is given such that the gluing maps γ_{xy} are linearly induced with the possible exception of $\gamma_{v\top}$. In order to prove that $\gamma_{v\top}$ is linearly induced we may re-coordinatize the L_x by means of linear maps.

Choose a such that Ra is the maximal ideal of R . Let e_0, e_1, e_2, \dots be a basis of M_0 associated with the basis a_0, a_1^n, a_2^n, \dots . In view of Corollary 7.2, after re-coordinatization of M_u there is a basis f_0, f_2, f_1, \dots of M_u completing e_0, e_2, e_1, \dots to a strictly a -synchronized pair of bases associated with the basis a_0, a_2^n, a_1, \dots of $L_0 \cup L_u$. By the same token, we obtain a basis g_0, g_1, g_2, \dots of M_v completing e_0, e_1, e_2 a strictly a -synchronized pair of bases associated with the

basis a_0, a_1^n, a_2, \dots of $L_0 \cup L_v$. Finally, one produces a basis h_0, h_1, h_2, \dots of M_\top completing f_0, f_1, f_1, \dots to a strictly a -synchronized pair of bases associated with the basis $u + a_0, u + a_1, u + a_2, \dots$ of $L_u \cup L_\top$. See Fig.2.

Again, we denote an element of L_S by the corresponding element of $L(RM_x)$ - for all suitable x . Then we get

$$\begin{aligned} & R(rg_0 + sg_1 + tag_2 + \sum_{i>2} r_i g_i) + P^{n-1}g_1 \\ &= R(re_0 + se_1 + te_2 + \sum_{i>2} r_i e_i) + P^{n-1}e_1 + P^{n-1}e_2 \\ &= R(rf_0 + saf_1 + tf_2 + \sum_{i>2} r_i f_i) + P^{n-1}f_2 = R(rh_0 + sah_1 + tah_2 + \sum_{i>2} r_i h_i). \end{aligned}$$

Now, $R(g_0 + g_2) + P^{n-1}g_1$ (i.e. its image under $\gamma_{v\top}$) is an axis for Rh_0 and Rh_2 in $L(RM_\top)$ hence by Lemma 6.3 there is an $s \in R^*$ such that

$$\begin{aligned} R(g_0 + g_2) + P^{n-1}g_1 &= R(h_0 + sh_2) \\ R(ah_0 + ash_2) &= (R(h_0 + sh_2))^{n-1} = (R(g_0 + g_2))^{n-1} + P^{n-1}g_1 \\ &= R(ag_0 + ag_2) + P^{n-1}g_1 = R(ah_0 + ah_2). \end{aligned}$$

The reader should be warned that $(Rg)^k$ has rank $\leq k$ while $P^k g$ has corank $\geq k$ in Rg . It follows $a = as$ whence with $h'_2 = sh_2$ we have

$$R(g_0 + g_2) + P^{n-1}g_1 = R(h_0 + h'_2) \quad \text{and} \quad ah'_2 = ah_2.$$

Replacing h_2 by h'_2 we achieve that g_0, g_2, g_1, \dots and h_0, h_2, h_1, \dots form an a -synchronized pair associated with the basis $v + a_0, v + a_2, v + a_1, \dots$ of $L_v \cup L_\top$. Let α be the unique automorphism of R inducing $\gamma_{v\top}$ according to Theorem 7.1. In particular,

$$\top + R(g_0 + g_1 + rg_2) = R(h_0 + ah_1 + \alpha(r)h_2).$$

We have to show that α is the identity map. Modifying the case of division rings ([8] Theorem 3.1), given any $r \in R$ we put

$$A_0 = Rf_1, \quad A_1 = R(f_0 + \alpha(r)f_1 + f_2), \quad A_2 = R(f_0 + f_1)$$

$$B_0 = Rg_2, \quad B_1 = R(g_0 + g_1 + rg_2), \quad B_2 = R(g_0 + g_2)$$

and obtain

$$\begin{aligned} A_0 + B_0 &= A_0 + \top + B_0 = Rh_1 + Rh_2 \\ A_1 + B_1 &= A_1 + \top + B_1 = R(h_0 + \alpha(r)h_1 + ah_2) + R(h_0 + ah_1 + \alpha(r)h_2) \end{aligned}$$

$$\begin{aligned}
A_2 + B_2 &= A_2 + \top + B_2 = R(h_0 + h_1) + R(h_0 + h_2) \\
(A_0 + B_0) \cap (A_1 + B_1) &\leq R(\alpha(r) - a)(h_1 - h_2) \leq A_2 + B_2.
\end{aligned}$$

By the Arguesian law it follows $C_2 \leq C_0 + C_1$. We put $s = \alpha(r)$ and compute

$$\begin{aligned}
C_1 &= (Rf_0 + Rf_1) \cap 0^+ \cap (Rg_0 + Rg_2) = (Re_0 + Re_1) \cap (Re_0 + Re_2) = Re_0 \\
C_2 &= (Rf_1 + R(f_0 + f_2)) \cap 0^+ \cap (Rg_2 + R(g_0 + g_1)) \\
&= (Re_1 + R(e_0 + e_2)) \cap (Re_2 + R(e_0 + e_1)) = R(e_0 + e_1 + e_2) \\
(A_1 + A_2) \cap 0^+ &= (R(f_0 + f_1) + R(f_0 + sf_1 + f_2)) \cap (Rf_0 + Raf_1 + Rf_2) \\
&= \{(x + y)f_0 + (xs + y)f_1 + xf_2 \mid x, y \in R, xs + y \in Ra\} \\
&= \{(x - xs + ta)f_0 + taf_1 + xf_2 \mid x, t \in R\} \\
&= R((1 - s)f_0 + f_2) + R(af_0 + af_1) = R((1 - s)e_0 + e_2) + R(ae_0 + e_1).
\end{aligned}$$

Similarly

$$(B_1 + B_2) \cap 0^+ = R((1 - r)e_0 + e_1) + R(ae_0 + e_2).$$

From $C_2 \leq C_0 + C_1$ and $C_1 + C_2 \leq 0^+$ we have

$$C_2 \leq (A_1 + A_2) \cap (B_1 + B_2) \cap 0^+ + C_1.$$

In particular, there are $x, y, p, q, z \in R$ such that $e_0 + e_1 + e_2 = v + ze_0$ with

$$v = x((1 - \alpha(r))e_0 + e_2) + y(ae_0 + e_1) = p((1 - r)e_0 + e_1) + q(ae_0 + e_2).$$

It follows

$$x(1 - \alpha(r)) + ya = p(1 - r) + qa = 1 - z, \quad y = p = 1, \quad x = q = 1$$

whence $\alpha(r) = r$. □

Proof of the Corollaries. The first is immediate by Prop.1.2. For the second, consider the geometric decomposition of L and fix a coordinatization of L_0 . Adjust the coordinatization of L_y by recursion on the height of y in $S_+(L)$: choose $y \prec x$ and apply Corollary 7.2 to $[y, x^+]$. We have to show by induction that each gluing map γ_{zx} is linearly induced. If z is the chosen y , this is so by construction. Otherwise, with $w = y \cap z$ we have $w \prec y, z \prec x$ and γ_{wy} and γ_{wz} linearly induced by inductive hypothesis. Then so is γ_{zx} by Theorem 8.1. Also, Theorem 8.1 implies the commutativity condition for the inducing linear maps. □

9 Isomorphism invariants

In general, a primary Arguesian lattice is not determined by its prime skeleton together with the isomorphism type of each block. A counterexample is given by the lattices $L({}_R R^3)$ and $L({}_S S^3)$ where R is the integers modulo p^2 and $S = F[x]/(x^2)$, F the p -element field - here all the skeletons and blocks are projective planes of order p . This is why we have to consider the geometric decomposition. By Corollary 7.4 for a primary Arguesian lattice of breadth ≥ 3 there is up to isomorphism only one coordinate ring R of maximal intervals of $\mathbf{gd} \geq 3$. Thus, if (k_1, \dots, k_r) is the type of L we may define the *extended type* as $(k_1, \dots, k_r; R)$. In particular, $\sum k_i \geq 3$ and R is a CPU ring the rank of which is the minimal l such that $\sum_{i=1}^r k_i \geq 3$. This is meant, if we speak of an extended type, abstractly.

In breadth 2 primary lattices, blocks may have distinct cardinalities. We say that a lattice is *q-uniform* if every length two interval that is not a chain has q atoms. For primary Arguesian lattices of breadth ≥ 3 one has q the number of 1-dimensional subspaces of a 2-dimensional R/P -vector space. For q -uniform breadth 2 semi-primary lattices we introduce the *extended type* $(k, l; q)$ where c_1, c_2 is a basis with $h(c_1) = k \geq h(c_2) = l$. Observe that $q = 2$ means that L is a direct product of two chains. Abstractly, an extended type is a triple of cardinals $q \geq 2$ and finite $k \geq l \geq 1$. The extended type of a chain is its height.

THEOREM 9.1. *The extended type is a complete isomorphism invariant for uniform primary Arguesian lattices.*

COROLLARY 9.2. *For any two primary Arguesian lattices L, L' of the same extended type and ordered bases of L and L' there is a basis preserving isomorphism. Moreover, if L, L' are of breadth ≥ 3 with given linear local coordinatizations then the isomorphism can be chosen locally linear.*

Proof. In the case of L, L' of breadth ≥ 3 and the same extended type, in view of Corollary 6.6 and 8.3 we may choose linear local coordinatizations $M_x (x \in S_+(L))$ and $M'_x (x \in S_+(L'))$ of L and L' over the same ring R . We show the following by induction on $S_+(L)$.

- (i) If $u \in S_+(L)$ and $u' \in S_+(L')$ are coatoms of the same type fitting into bases of L and of L' according to Corollary 4.4, then every locally linear isomorphism $\varphi : (u^+] \rightarrow (u'^+]$ preserving the induced bases can be extended to a basis preserving locally linear isomorphism of L onto L' .
- (ii) If $u \in S_+(L)$ and $u' \in S_+(L')$ are coatoms of the same type then every locally linear isomorphism of $(u^+]$ onto $(u'^+]$ can be extended to a locally linear isomorphism of L onto L' .
- (iii) For any ordered bases of L and L' there exists a basis preserving locally linear isomorphism of L onto L' .

If $S_+(L)$ is 1-element, then (i) and (ii) are void. $M_0 \cong M'_0$ since they are of the same type and by Corollary 6.2 any ordered bases can be matched.

In the inductive step, assume that ordered bases a_1, \dots of L and a'_1, \dots of L' are chosen as required in (i). By assumption, φ is induced by a linear isomorphism $\Phi_x : M_x \rightarrow M'_{\varphi x}$ ($x \in (u]$). We have to define Φ_x for the remaining $x \in S_+(L)$ so that we obtain a linear isomorphism inducing a basis preserving isomorphism. Depending on the type of u we have $j \in \{1, 2\}$ such that $u + a_j$ and $u' + a'_j$ are cycles of maximal rank in $L_u \cup L_\top$ and $L'_u \cup L'_\top$, respectively, and we may choose Φ_\top according to Corollary 7.3 such that $\hat{\Phi}_\top(u + a_j) = u + a'_j$. If $S_+(L)$ is a chain then $j = 1$, $a_1 = u + a_1$ and $a'_1 = u' + a'_1$ and we are done. Otherwise, in each of $S_+(L)$ and $S_+(L')$ we have a unique second coatom v resp. v' fitting into the given basis and $\varphi(v) = v'$. Let $w = u \cap v = \top_*$ and $w' = u' \cap v' = \varphi w = \top'_*$. Then for any coatom $x \neq u$ of $S_+(L)$ we may apply the inductive hypotheses to the coatoms $w \in (x]$ and $w' \in (\varphi x]$ and the restriction of φ to $(w^+]$. Namely, we apply (i) for $x = v$ and (ii), else. Thus, for each $x \in S_+(L)$ we have a well defined $\Phi_x : M_x \rightarrow M'_x$. Moreover, the compatibility condition $\hat{\Phi}_y \circ \gamma_{xy} = \gamma'_{xy} \circ \hat{\Phi}_x$ is satisfied a fortiori if $y \neq \top$ or if $x = u$ and follows from Corollary 8.2 if $y = \top$. The induced isomorphism of L onto L' is basis preserving, since the isomorphisms on $(u^+]$ and $(v^+]$ are basis preserving and since the basis of L is contained in $(u^+]$ \cup $(v^+]$. To prove (ii) just choose bases for u and u' according to Corollary 4.4 and apply (i). To prove (iii) choose coatoms u and u' fitting into the bases, analogously. In particular, u and u' are of the same type and so are u^+ and u'^+ . By the inductive hypothesis (iii) there is a locally linear isomorphism φ of $(u^+]$ onto $(u'^+]$ preserving the induced bases. φ matches the top elements \top of $S_+(L)$ and \top' of $S_+(L')$ and restricts to an isomorphism between $S_+(L)$ and $S_+(L')$. Hence, we can apply (i) to get the required isomorphism of L onto L' .

In the case of breadth 2, by inductive hypothesis we have an isomorphism φ matching the basis $a_1^{h_1-1}, a_2^{h_2-1}$ of $S(L)$ with the basis $a'_1{}^{h_1-1}, a'_2{}^{h_2-1}$ of $S(L')$. Due to breadth 2 the a_i and a'_i are also dual cycles, whence doubly irreducible. Since they are also in corresponding blocks, the proof of the following lemma yields an isomorphism mapping a_i onto a'_i . \square

LEMMA 9.3. *Let L and L' be semi-primary lattices of breadth ≤ 2 and $\varphi : S(L) \rightarrow S(L')$ an isomorphism such that for each $x \in S(L)$ the intervals $[x, x^*]$ and $[\varphi(x), \varphi(x)^*]$ are of the same cardinality. Then φ extends to an isomorphism of L onto L' .*

Proof. Induction on height. Choose a coatom c in $S(L)$. Then c^* is a coatom in L and $\varphi(c)^*$ a coatom in L' . Moreover, the ideals (c^*) and $(\varphi(c)^*)$ have prime skeletons $(c]$ and $(\varphi c]$ and, by inductive hypothesis, $\varphi|(c]$ extends to an isomorphism ψ between them. Next, choose an atom a in $S(L)$. Then the filters $[a)$ and $[\varphi a)$ have prime skeletons $[a, 1_*)$ and $[\varphi a, \varphi 1_*)$ matched by $\varphi|[a) = \psi|[a, 1_*)$, so this extends to an isomorphism, again by inductive hypothesis. This provides

us with an isomorphism χ of $(c^*) \cup [a]$ onto $(\varphi(c)^*) \cup [\varphi a]$. Since this takes care of the skeleton and its dual, as well, all remaining elements have to be doubly irreducible (in breadth 2 every meet-reducible is in $S(L)$, obviously). Hence, for each $x \in S(L)$ we may choose an isomorphism χ_x of $[x, x^*]$ onto $[\varphi x, \varphi(x)^*]$ which coincides with χ where this is defined. Now, observe that for $x \prec y$ in $S(L)$ we have $[x, x^*] \cap [y, y^*] = \{y, x^*\}$. Hence Lemma 1.1 provides an extension of φ to an isomorphism of L onto L' . \square

10 Coordinatization

THEOREM 10.1. *For any extended type $(k, l; q)$ there exist up to isomorphism exactly one semi-primary lattice of this type. For any extended type $(k_1, \dots, k_r; R)$ there is up to isomorphism exactly one primary Arguesian lattice of this type.*

COROLLARY 10.2. *A lattice L is coordinatizable (by a finitely generated module over a CPU ring A) if and only if it is one of the following*

- (1) a finite chain
- (2) q -uniform primary of breadth 2 with $q = p^k + 1$, p prime, or q infinite
- (3) primary Arguesian of breadth ≥ 3

A can be chosen as a factor ring of $F[x]$, F a field, if and only if (1) or (2) with $|F| = p^k$, ∞ or (3) with the coordinate ring a factor ring of $F[x]$. L is isomorphic to the subgroup lattice of a finite Abelian p -group if and only if (1) or (2) with $k = 1$ or (3) with coordinate ring $\mathbb{Z}/(p^n)$.

Proof. Uniqueness has been shown in the preceding section. Existence. We claim that a lattice of type $(k, l; q)$ can be constructed as a sublattice of $L(M)$ where F is a field such that $|F| + 1 \geq q$ and $M = R \times F[x]/(x^l)$ the module over the CPU $R = F[x]/(x^k)$. Observe that $L(M)$ is of type $(k, l; |F| + 1)$ and that, by inductive hypothesis, we have a type $(k-1, l-1; q)$ sublattice S of $[0, 1_*$] (where $0 - 1 := 0$). Then $x \mapsto x^*$ is an isomorphism of S onto a sublattice S^* of $[0^*, 1]$. Since $[x, x^*]$ is a height 2 interval with at least q atoms, for each $x \in S$ we may choose a height 2 sublattice L_x with q atoms containing $[x, x^*] \cap (S \cup S^*)$. Then the S -glued sum L has prime skeleton S and dual prime skeleton S^* which both are interval sublattices of S , so L is semi-primary and has the required type by Theorem 3.1 and its corollary.

In the breadth ≥ 3 case, choose by Theorem 5.2 a CPU ring A having rank of L and R as a homomorphic image. With Q the maximal ideal of A let

$$M = \bigoplus_{i=1}^r (A/Q^i)^{k_i}$$

considered as an A -module. $L({}_A M)$ is primary of the required extended type. \square
 By Inaba's result [15], every primary lattice of geometric dimension ≥ 4 is Arguesian.

PROBLEM 10.3. *Is every primary lattice of breadth ≥ 4 Arguesian?*

COROLLARY 10.4. *A primary lattice is Arguesian if and only if it admits a cover preserving embedding into a coordinatizable lattice.*

This is in contrast to the examples of Haiman [10] of Arguesian lattices not having even a representation by lattices of permuting equivalences. These lattices have finite distributive prime skeleton and blocks which are projective geometries over the same field. Yet, the skeletons fail to be cover preserving or sublattices. This fact and known partial results (cf. the survey in [14]) gives some credit to the following. Also, one observes that Theorems 7.1 and 8.1 only required the Arguesian law for the special gluings, considered (in 7.1 the resulting lattice is primary, of course).

PROBLEM 10.5. *Does every semi-primary lattice satisfying the Arguesian law resp. its higher dimensional versions admit a representation by permuting equivalences?*

For finite Abelian p -groups of the same order, embeddings of one subgroup lattice into another have been studied by Barnes [3] and Schmidt [24]. Nontrivial such exist only if the embedded lattice has a type with $\sum_{i>1} k_i \leq 2$.

PROBLEM 10.6. *How have the finitely generated modules ${}_R M$ and ${}_S N$ over CPU rings to be related in order that there exists a cover preserving 0-1-embedding of $L({}_R M)$ into $L({}_S N)$?*

References

- [1] V. A. Antonov and Yu. A. Nazarova. Layer-projective lattices. *Math. Notes* 63: 150–160, 1998.
- [2] H.-J. Bandelt. Tolerance relations on lattices. *Bull. Austral. Math. Soc.* 23: 367–381, 1981.
- [3] D. W. Barnes. Lattice embeddings of prime power groups. *J. Austral. Math. Soc.* 2: 17–34, 1962
- [4] L. M. Butler. Subgroup lattices and symmetric functions. *Memoirs Amer. Math. Soc.* 539, Providence RI, 1994

- [5] V. P. Camillo, Inducing lattice maps by semi-linear isomorphisms. *Rocky Mountain J. Math.* 14: 475–486, 1984
- [6] P. Crawley and R. P. Dilworth. Algebraic Theory of Lattices. Englewood Cliffs NJ, 1973.
- [7] A. Day and C. Herrmann. Gluings of modular lattices. *Order* 5: 85–101, 1988.
- [8] A. Day, C. Herrmann, B. Jónsson, J. B. Nation and D. Pickering. Small non-Arguesian lattices. *Algebra Universalis* 31: 66–94, 1994.
- [9] M. Ezzeldin. Präprimäre Verbände. *Beiträge zur Algebra und Geometrie* 28: 83–97, 1989.
- [10] M. Haiman. Arguesian lattices which are not type-1. *Algebra Universalis* 28: 128–137, 1991.
- [11] C. Herrmann. S -verklebte Summen von Verbänden. *Math. Z.* 130: 255–274, 1973.
- [12] C. Herrmann. Quasiplanare Verbände. *Arch. Math.* 24: 240–245, 1973.
- [13] C. Herrmann. On the arithmetic of projective coordinate systems. *Trans. Amer. Math. Soc.* 284: 759–785, 1984
- [14] C. Herrmann. On Alan Day’s work on modular and Arguesian lattices. *Algebra Universalis* 34: 35–60, 1995
- [15] E. Inaba. On primary lattices. *J. Fac. Sci. Hokkaido Univ.* 11: 39–107, 1948
- [16] B. Jónsson. Arguesian lattices of dimension $n \leq 4$. *Math. Scand.* 4: 193–208, 1959
- [17] B. Jónsson. Representations of complemented modular lattices. *Trans. Amer. Math. Soc.* 97: 64–94, 1960.
- [18] B. Jónsson, Equational classes of lattices. *Math. Scand.* 22: 187–196, 1968.
- [19] B. Jónsson and G. Monk. Representation of primary Arguesian lattices. *Pacific J. Math.* 30: 95–130, 1969.
- [20] J. B. Nation and D. Pickering. Arguesian lattices whose skeleton is a chain. *Algebra Universalis* 24: 91–100, 1987.
- [21] D. Pickering. Minimal non-Arguesian lattices. Ph.D. Thesis, University of Hawaii, 1984.

- [22] H. Ribeiro. “Lattices” des groupes abéliens finis. *Comm. Math. Helv.* 23: 1–17, 1949.
- [23] R. Schmidt. Subgroup lattices of groups. *De Gruyter Exp. in Math.* 14, Berlin, 1994
- [24] R. Schmidt. Lattice embeddings of abelian prime power groups. *J. Austral. Math. Soc. (ser. A)* 42: 259–278, 1997
- [25] V. A. Antonov and Yu. A. Nazyrova. Layer=projective lattices II.. *Math. Notes* 72 : 145–151, 2002.
- [26] V. A. Antonov and Yu. A. Nazyrova. About primary lattices of large geometric dimension. *Acta Appl. Math.* 85: 17–23, 2005.
- [27] L. Guidici. Dintorni del teorema di coordinatizzazione di von Neumann, Appendice D: Reticoli fortemente semimodulari semiprimari. *tesi di Dottorato, Univ. degli studi di Milano* 1995, <http://nolay/nat/mat/mat.html>
- [28] C. Herrmann and A. P. Huhn. Zum Begriff der Charakteristik modularer Verbände, *Math. Z.* 144: 185–194, 1975.
- [29] G. S. Monk. Desargues Law and the representation of primary Arguesian lattices. *Pacific J. Math.* 30: 175–186, 1969.
- [30] F. Regonati and S. Sarti. Enumeration of chains in semi-primary lattices. *Ann. of Comb.* 4: 109–124, 2000.
- [31] G. P. Tesler. Semi-primary lattices and tableau algorithms. *PhD thesis MIT* 1995. <http://mat.ucsd.edu/gptesler>